

LAS8007 si Drop Seal

Heavy Duty



Description

This heavy duty fully mortised aluminium automatic drop seal features a silicone rubber gasket and internal fins. It is used to close the gap under single swing doors to maintain the acoustic, smoke and energy efficiency performance. The seal incorporates a high efficiency spring loaded mechanism that extends the seal as the door swings shut and automatically retracts it as the door is opened by just a few centimetres.

Key benefits

Dual internal sealing fins enhance acoustic and smoke containment performance.

Supplied with high performance fire rated silicone rubber gasket.

Fully automatic, no power connection required.

Simple adjustment to suit varying door gap requirements.

Proven long term reliability.

Approvals

Fire: Approved for use on proprietary AS1905.1 fire doors for up to 4 hour fire rating.

Smoke: Medium temperature smoke approvals for use on AS6905 compliant smoke door assemblies. Conforms with BCA Specification C3.4 smoke sealing requirements.

Sound: Acoustically tested in accordance with ISO10140-2 and AS/NZS717.1 with ratings up to 40Rw on appropriate rated assemblies.

Durability: Long term mechanical test, completing 1,000,000 cycles without failure.

Standard lengths

820mm (may be trimmed back to 720mm)

920mm (may be trimmed back to 820mm)

1070mm (may be trimmed back to 920mm).

Fixing method

Fixing screws are supplied, fixing holes are pre-drilled through the flanges.

Gap sizes

Up to 15mm.

Finishes

Silver anodised aluminium, grey silicone rubber gasket, grey end caps.

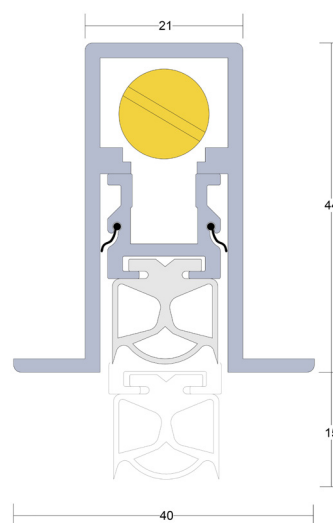

LAS8007 si

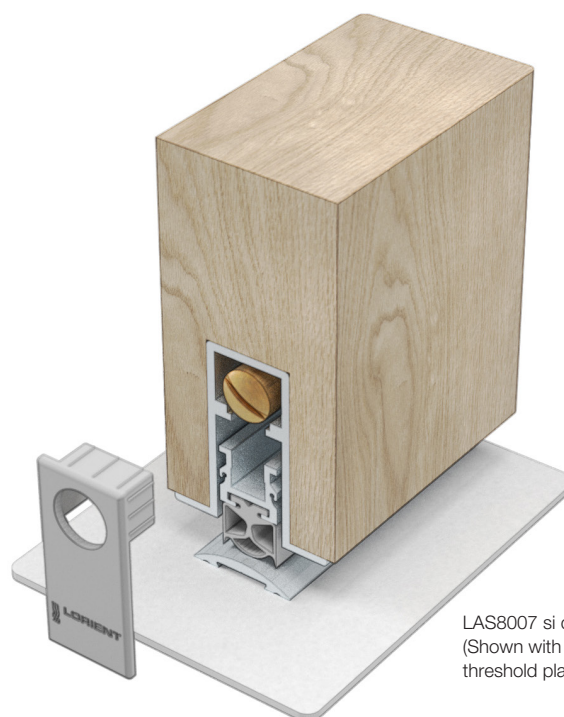

LAS8007 si drop seal
(Shown with LAS4002
threshold plate)